

ZAR

ZARFORMENTI

BUILT IN ITALY. DESIGNED WITH PASSION



www.zar-formenti.com

ZAR, UNA STORIA DI SUCCESSO · ZAR, A HISTORY OF SUCCESS

1992: nasce il primo ZAR.

Ed è un'autentica rivoluzione nel mondo dei battelli pneumatici.

Carena superperformante, comfort assoluto, grandi spazi abitativi, qualità costruttiva, design rivoluzionario: un'innovazione totale! Ne è passata di acqua sotto i ponti – o meglio sotto alle carene – da allora ad oggi, ma ZAR è tuttora il benchmark universale, il riferimento per antonomasia.

Con lo scorrere degli anni lo ZAR si è moltiplicato, modello dopo modello, per soddisfare le tante esigenze dei clienti, sono cambiate le tecniche di progettazione, ora totalmente computerizzate, si sono evoluti i materiali, si sono arricchiti gli accessori, si sono ottimizzate le metodologie di lavorazione.

Ma non sono cambiati i concetti fondamentali che ne hanno guidato la nascita e la sua continua evoluzione e che ne fanno un autentico prodotto premium:

- qualità della navigazione: prestazioni, comfort, sicurezza in un connubio ineguagliato;
- qualità della vita a bordo: ampi spazi per persone e bagagli, accessori ricercati, cura maniacale del dettaglio;
- qualità della costruzione: i materiali più performanti e le lavorazioni più accurate per una grande durata che ne mantenga alto il valore nel tempo;
- qualità del design: la funzionalità vestita in modo esclusivo e ricercato, un'impronta inconfondibile.

ZAR, una grande storia che continua più attuale che mai.



1992: the first ZAR is born.

It is an authentic revolution in the world of Rigid Inflatable Boats.

Superperformance hull, absolute comfort, great living space, constructive quality, revolutionary design: it is a total innovation!

There has been water ran under the bridges - or rather beneath the hull - since then, but ZAR is still the universal benchmark, the reference par excellence.

Over the years ZAR has multiplied, model after model, to meet the many needs of customers. ZAR has changed the design techniques and is now totally computerized through the use of CAD and CNC machinery for mold design. The materials have evolved, the accessories have been enhanced, they have optimized the Methodologies of processing and manufacturing. But the basic concepts that led to its birth and its continuous evolution have not changed, and make it a true premium product:

- *Navigation quality: performance, comfort, safety in unmatched combination.*
- *Quality of life on board: ample spaces for passengers, wide stowages, desirable accessories, maniacal detail care.*
- *Quality of construction: the most performing materials and the most accurate machining for a long life that keeps it high over time.*
- *Design quality: the exclusive and sought-after functionality, an unmistakable impression.*

ZAR, a great story that continues more contemporary than ever.

ZAR, L'HISTOIRE D'UN SUCCÈS · ZAR, EINE ERFOLGSGESCHICHTE

1992: le premier ZAR sort de l'usine Formenti.

... et c'est une véritable révolution dans le monde du semi-rigide.

Carène très performante, confort absolu, grands espaces habitables, qualité de construction, design futuriste: une innovation unique.

Depuis beaucoup d'eau est passée sous les ponts-ou mieux- sous nos carènes mais ZAR reste la référence dans le milieu de la plaisance.

Avec les années la gamme a grandi; pour satisfaire les exigences des utilisateurs les technologies ont évolué et nous avec elles; désormais les projets réalisés sur ordinateur la gamme enrichie et adaptée selon nos idées et celles de nos fidèles clients, l'évolution des matériaux, l'optimisation des procès de production.

Mais notre philosophie qui a donné naissance aux ZAR n'a pas changé:

- les qualités de navigation , prestations, confort et sécurité incomparables ;
 - qualité de vie à bord qui se traduit par de nombreuses places assises, grands coffres pour stocker le matériel, accessoires recherchés et le soin du détail quasiment maniacal ;
 - qualité de construction, des matériaux performants et une réalisation soignée pour une longue durée du produit ;
 - qualité du design car l'esthétique n'est pas suffisante si elle ne se montre pas fonctionnelle ;
- ZAR, histoire d'un succès plus actuel que jamais



1992: Wurde das erste ZAR geboren.

Es ist eine Revolution in der Welt der Festrumpfschlauchboote.

Erstklassiger Rumpf, absoluter Komfort, viel Platz an Bord, Konstruktion in Bestform, revolutionaries Design. Es ist eine komplette Innovation!

Viel Wasser ist die Flüsse entlanggeflossen oder unter den Rümpfen hindurch, aber ZAR ist immernoch die Referenz par excellence.

Über die Jahre hat sich das erste ZAR vervielfacht und immer mehr Modelle wurden erschaffen um die unterschiedlichen Kundenbedürfnisse zu befriedigen. ZAR hat die Konstruktionstechnik geändert und ist nun durch die Nutzung von CAD und CNC Maschinen, für das Rumpfdesign, vollständig digitalisiert worden. Die Materialien haben sich entwickelt, das Zubehör wurde erweitert, und die Methoden der Verarbeitung und Fertigung haben sich optimiert. Aber die grundlegenden Konzepte, die zu seiner Geburt und ihrer kontinuierlichen Entwicklung geführt haben, haben sich nicht geändert und machen es zu einem wahren Premiumprodukt:

- *Navigationsqualität: Leistung, Komfort, Sicherheit in unerreichter Kombination.*
- *Lebensqualität an Bord: reichlich Platz für Passagiere, breite Stauräume, wünschenswertes Zubehör, besessene Detailpflege.*
- *Qualität des Aufbaus: die leistungsstärksten Materialien und die genaueste Bearbeitung für ein langes Leben, das den Wert vom Boot im Laufe der Zeit stabil hoch halt.*
- *Designqualität: die exklusive und begehrte Funktionalität, ein unverwechselbarer Eindruck.*

ZAR, eine großartige Geschichte, die zeitgenössischer als je zuvor weiterführt.

IL PROGETTO E LA TECNOLOGIA

Il progetto di un nuovo ZAR nasce oggi dal centro informatico dotato delle più evolute applicazioni di modellizzazione 3d in campo nautico. Carena e coperta si integrano in un progetto unitario perché tutto, dal design al bilanciamento delle masse, dalla gestione degli spazi al centro di spinta del galleggiamento abbia la massima resa in tutte le condizioni di navigazione.

Non mancano le prove in acqua dei prototipi per l'affinamento e l'ottimizzazione prima del passaggio alla produzione. I modelli "reali" da cui si ricavano gli stampi delle componenti in VTR sono prodotti da gigantesche frese a controllo numerico guidate direttamente dai modelli "virtuali" prodotti dal centro informatico. Il risultato è una notevole precisione nel passaggio dal teorico al reale.

La costruzione di uno ZAR comincia e finisce in tre stabilimenti in cui vengono prodotti e scrupolosamente controllati i tubolari, scelti i tessuti delle cuscinerie, preparati gli elementi in acciaio inox, acquistati gli accessori di terze parti. L'assemblaggio finale è il risultato della gestione aziendale del delicato equilibrio fra alto artigianato e rigore tecnico, della magia delle mani dell'uomo e la potenza della tecnologia più evoluta.

È nato un nuovo ZAR.

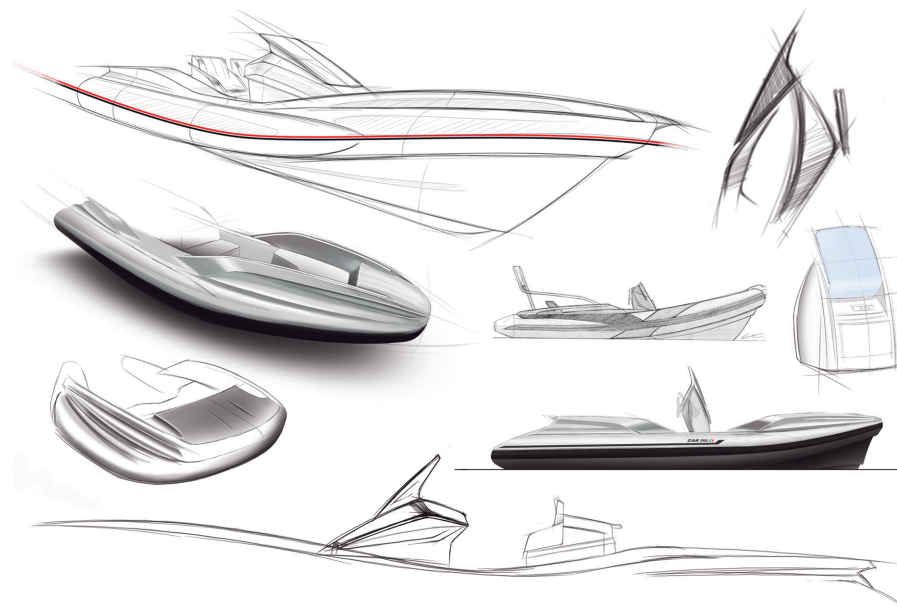

THE PROJECT AND TECHNOLOGY

The design of a new ZAR is developed today by the computer center equipped with the most advanced 3d modeling applications in the nautical field. Deck and blanket integrate into a one-piece design because everything from design to mass balance, from space management to floating propulsion center has maximum yield in all navigation conditions.

There is an accurate prototype testing in the water for refining and optimization prior to production. The "real" models from which the components molds are made in VTR are produced by giant numerical control grids directly guided by the "virtual" models produced by the computer center. The result is a remarkable precision in passing from the theoretical to the real.

The construction of a ZAR begins and ends in three factories where the tubes are selected and scrupulously controlled, selected cushion fabrics, prepared stainless steel elements, and purchased third-party accessories. The final assembly is the result of the company's management of the delicate balance between high craftsmanship and the technical rigor, from man's magic hands and the power of the most advanced technology.

A new ZAR is born.

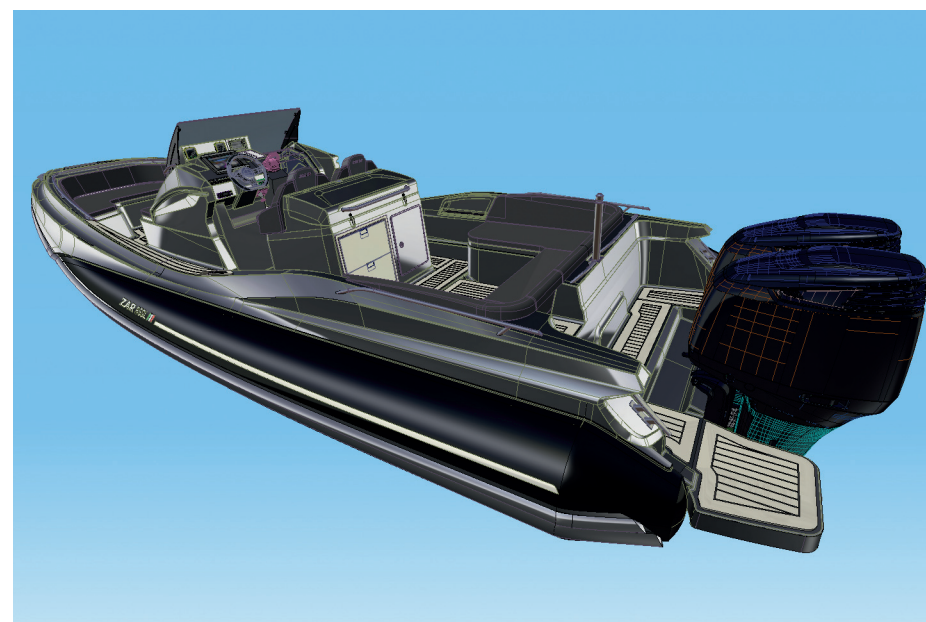



La création d'un nouveau Zar passe premièrement par les technologies plus évoluées du dessin en 3D dans le secteur du nautisme. Carène et pont se fondent dans un projet unique qui tient compte du design, de la répartition des poids, la gestion des espaces de vie à bord et bien d'autres paramètres afin que le bateau donne le meilleur de soi-même dans n'importe quelles conditions de navigation.

Avant la mise en production de chaque modèle, des tests de navigation sur plan d'eau sont effectués pour apporter des améliorations au bateau que nous vous proposons.

Les moules sont réalisés par des machines à contrôle numérique guidée par le dessin virtuel du projet. Le résultat est une précision absolue du passage entre les idées des créateurs et dessinateurs et le produit réel.

La construction d'un ZAR se développe autour de 3 espaces de production où le tissu exclusivement CR/CSM est découpé, poncé et collé pour la réalisation des flotteurs, où sont choisis les tissus des coussins de bord, préparé l'accastillage de bord et acheminés les matériaux des fournisseurs. L'assemblage final c'est le résultat d'une réalisation artisanale et une gestion rigoureuse là où le travail de l'homme rencontre la technologie plus évoluée.

KONZEPT UND TECHNOLOGIE

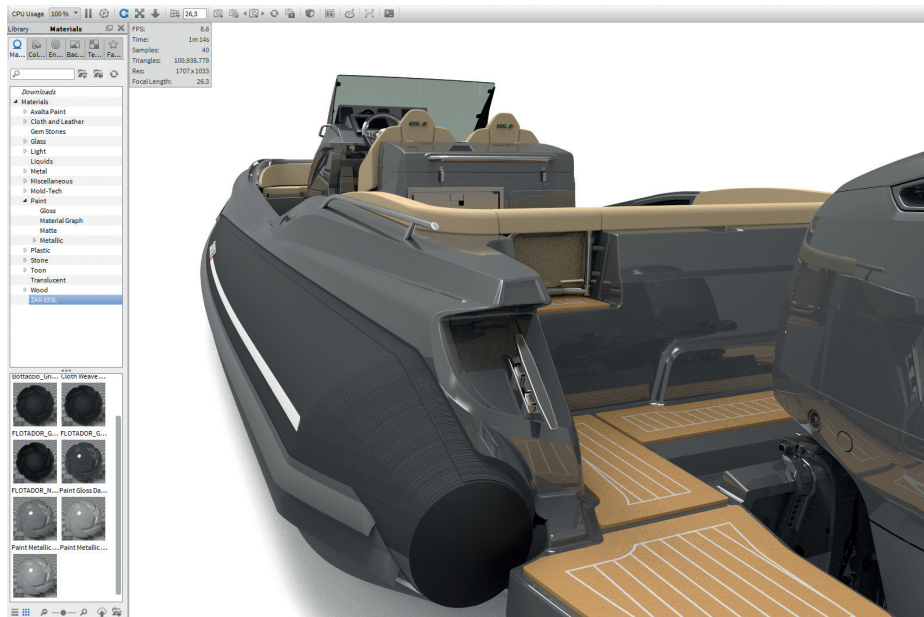

In einem mit einer der am höchsten entwickelten 3D-Modellierungsanwendungen im Bereich der Schifffahrt ausgestatteten Informatikzentrum hat das Konzept eines neuen ZAR-Bootes heutzutage seine Geburtsstunde. Schiffsboden und Deck integrieren sich in ein einheitliches Konzept, denn vom Design bis zum Massenausgleich, von der Platzverwaltung bis hin zum Schwimmfähigkeitsmittelpunkt, ist das Konzept unter allen Navigationsbedingungen höchst leistungsfähig.

Zur Verfeinerung und Optimierung werden vor dem Schritt in die Produktion Prototypenwassertests durchgeführt. Die „realen“ Modelle, aus denen die Gesenke der Glasfaserkunststoffteile entstehen, werden mit riesigen numerisch gesteuerten Fräsmaschinen hergestellt und direkt durch die „virtuellen“, im Informatikzentrum entstandenen Modelle gesteuert. Das Ergebnis ist eine bemerkenswerte Präzision beim Übergang von der Theorie in die Praxis.

Der Bau eines ZAR-Bootes beginnt und endet in drei Werken, in denen die röhrenförmigen Schläuche hergestellt und gewissenhaft kontrolliert, die Polsterstoffe ausgewählt, die aus rostfreiem Edelstahl bestehenden Elemente vorbereitet und die Zubehörteile externer Bereiche hinzugekauft werden. Die Endmontage ist das Ergebnis der betrieblichen Lenkung des empfindlichen Gleichgewichts zwischen hochwertigem Handwerk und technischer Genauigkeit, der Magie durch Menschenhand und der Stärke höchst entwickelter Technik.

Ein neues ZAR-Boot ist geboren.

LA CARENA

L'assenza del tubolare di prua e l'arretramento dello specchio di poppa fino al limite dei coni poppieri ha permesso di progettare la carena ZAR con lunghezza ben maggiore di quella di altri battelli di pari dimensioni e di conformarla con una "V" molto profonda a prua per un impatto sull'onda particolarmente morbido.

Dotata degli esclusivi "tunnel" laterali che aumentano la stabilità in velocità e la morbidezza in navigazione, la carena ZAR "annulla" i fastidiosi spruzzi laterali deflettendoli sotto ai tubolari in corrispondenza dei tunnel che li scaricano a poppa.

LA CARÈNE

Le choix, qui nous a démarqué des autres producteurs depuis 1992, de ne pas avoir les flotteurs sur la proue de nos bateaux et le repoussement du tableau de bord au niveau de la fin des flotteurs à poupe nous a permis depuis toujours d'avoir des bateaux avec une longueur de carène bien plus importante que celles des autres semi-rigides de même taille, qui se traduit aussi par un espace à bord plus important et la possibilité d'avoir une étrave très haute et un V très prononcé pour fendre les vagues et ainsi avoir un comportement en mer très souple.

Doté de tunnels latéraux (brevet ZAR), la carène augmente encore plus la sensation de souplesse ainsi que la stabilité à haute vitesse tout en éliminant les éclaboussures latérales.

THE HULL

The absence of the bow tube section and the aft backrest down to the edge of the aft cones made it possible to design the ZAR hull much longer than that of other boats of equal size and to conform a very deep "V" hull and sharp stern to perform the best smooth ride impact even in rough waters.

Equipped with exclusive "tunnels" that increase speed stability and softness in navigation, the ZAR hull "nullifies" the annoying side sprays deflecting them underneath the tubes and discharges them towards the transom area.

DER RUMPF

Der Verzicht auf die röhrenförmigen Bugschläuche und das Zurückfahren des Heckspiegels bis zur Begrenzung durch die Heckkegel hat die Konzipierung des ZAR-Rumpfes mit einer größeren Länge gegenüber Booten mit gleichen Ausmaßen erlaubt. Darüber hinaus kann der Rumpf mit einem viel tieferen "V" im Bugbereich gestaltet werden, um so einen sanfteren Wellenaufprall zu gewährleisten.

Dank seiner exklusiven seitlichen "Tunnelausstattung", die eine Geschwindigkeitsstabilität und ein weiches Navigieren erlaubt, gibt es bei den ZAR-Schlauchbooten keine störenden Seitenspritzer mehr. Diese werden unter die Röhren entlang der Tunnel abgelenkt, um achtern abzulaufen.

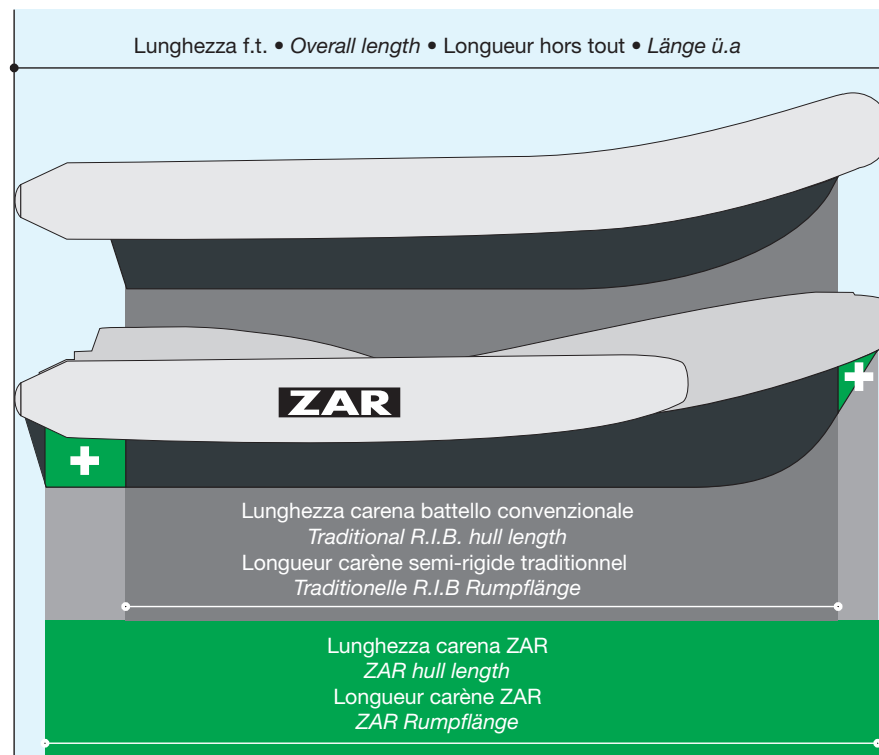

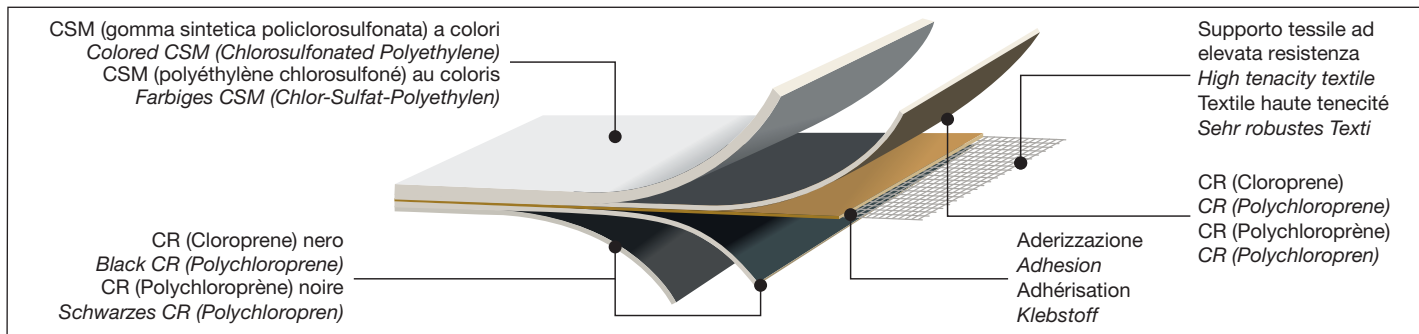







IL TESSUTO GOMMATO

Il Cantiere ZAR-Formenti utilizza per la costruzione delle parti gommate dei battelli ZAR esclusivamente i prodotti ORCA® della Pennel Industries: tessuto in Poliestere "High Tenacity" con rivestimento in CSM (gomma sintetica policlorosulfonata) e CR (cloroprene). I tubolari sono confezionati con coprigiunti interni ed esterni e la giunzione tra essi e la carena è doppia lungo tutto il perimetro.

COATED FABRIC

For the construction of the rubberized parts of ZAR boats, the manufacturer ZAR-Formenti exclusively uses ORCA® products from Pennel Industries: "High-Tenacity" polyester fabric with CSM (chlorosulfonated polyethylene) and CR (polychloroprene) coatings. The tubular elements are made with internal and external butt straps and a double junction between the tubulars and the fiberglass hull along the entire perimeter of the boat.



	Resistenza ai raggi ultravioletti Ultra violet light resistance	Résistance à la lumière (UV) UV - beständig.
	Resistenza al fuoco Fire resistance	Résistance au feu Feuerfest
	Resistenza all'abrasione Abrasion resistance	Résistance à l'abrasion Abnutzungsresistent
	Resistenza agli idrocarburi Hydrocarbon resistance	Résistance aux hydrocarbures Kohlenwasserstoffresistent.
	Riparazione del tubolare Tubular repairs	Réparation du flotteur Schlauchreparatur
	Resistenze meccaniche Mechanical resistance	Résistance mécaniques Mechanische Widerstandsfähigkeit
	Resistenza alle intemperie Extreme condition resistance	Résistance aux intempéries Extrem Witterungsbeständig

LE TISSU CAOUTCHOUTÉ

Le chantier ZAR-Formenti utilise exclusivement, pour la construction des parties pneumatiques, les produits ORCA des industries Pennel: tissu en polyester "high tenacity" revêtu de CSM (polyéthylènechloro sulfoné) et CR (Polychloroprène). Les flotteurs sont confectionnés au moyen de jointures collées à l'intérieur et à l'extérieur, les jointures raccordées à la carène sont doublées sur tout le périmètre.

DAS GUMMIERTE GEWEBE

Zur Herstellung der Schläuche verwendet die Formenti Werft nur ORCA® Produkte von Pennel Industries: Hochfestes Polyester mit Chlor-Sulfat-Polyethylen – und Polychloroprenbeschichtung. Die Schlauchelemente sind mit internen und externen Stoßnähten versehen und die Verbindungsstücke zwischen den Elementen sowie deren gesamter Umfang verfügen über eine doppelte Bootshaut.

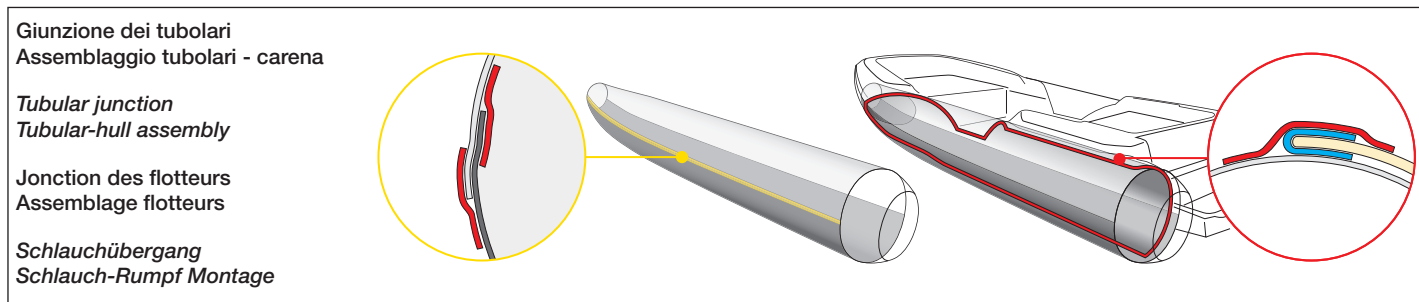

LO SPAZIO A BORDO

La conformazione della prua, liberata dall'ingombro del tubolare, ha reso disponibile una zona abitativa ampia e confortevole, con più posti a sedere e rapidamente trasformabile in prendisole a tutta larghezza grazie alla modularità della cucineria.

Il posto guida permette la condotta in piedi o da seduti e offre sempre una visuale perfetta di tutta la strumentazione.

La parte poppiera, fin dalle origini, è stata concepita come "salotto", con l'allontanamento del motore, l'estensione dei divani fin sopra ai tubolari e con l'applicazione sistematica del concetto di modularità: ne è risultata una zona polivalente comoda e sicura in navigazione, conviviale nelle soste e con la possibilità persino di ottenere un grande letto matrimoniale nella maggioranza dei modelli.

L'ESPACE DE VIE A BORD

L'un des points forts de nos bateaux est son habitabilité record! Sans flotteur à l'avant du bateau la largeur du bain de soleil avant augmente sensiblement en offrant un espace que les semi-rigides traditionnels ne peuvent pas avoir. Le poste de pilotage avec le siège modulable se transforme en leaning post avec une vision parfaite de l'horizon et des instruments. Nous avons pensé à l'arrière de nos bateaux comme à un salon de bord en repoussant plus loin le moteur en rehaussant nos banquettes au dessus des flotteurs grace à une étude de modularité unique qui permet de transformer les assises en bain de soleil sans avoir besoin de coussins supplémentaires. Pratiques en navigation, conviviaux au mouillage. Les coffres, nombreux et répartis sur tout la longueur du bateau, ils permettent de loger une quantité incroyable de matériel.

THE SPACE ON BOARD

The shape of the bow, free of the tubes, has made available a spacious and comfortable living area, with more seats and quickly transformable to a wide open sundeck thanks to the modularity of the cushions.

The driving seat allows for standing or sitting, and always offers a perfect view of all instrumentation.

The aft part, from its origins, was conceived as a "living room", the extension of the couch up to the tubes and with the systematic application of the concept of modularity is a convenient polyvalent area Safe in navigation, convivial while the boat at the anchor and with the ability to convert in a big double bed in most models.

PLATZ AN BORD

Die Buggestaltung ermöglicht ohne störende Röhrenführung eine geräumigere und bequemere Nutzfläche, wodurch eine größere Anzahl an Sitzplätzen entsteht, die wiederum über die gesamte Breite dank Polstermodulen schnell in Sonnenliegeflächen umgewandelt werden können. Der Bootsführerplatz erlaubt das Steuern im Stehen oder im Sitzen und bietet immer eine perfekte Sicht auf die gesamte instrumentelle Ausrüstung.

Der Heckbereich wurde durch und durch als eine Art "Wohnzimmer" konzipiert. Das heißt, vom Motor entfernt, Sofaflächen, die die röhrenförmigen Schläuche bedecken und konsequente Umsetzung des Baukastenprinzips. Somit entsteht ein bequemer Mehrzweckbereich, der darüber hinaus auch noch navigationssicher und während der Pausen benutzerfreundlich ist und bei den meisten Modellen außerdem die Option eines geräumigen Ehebetts bietet.

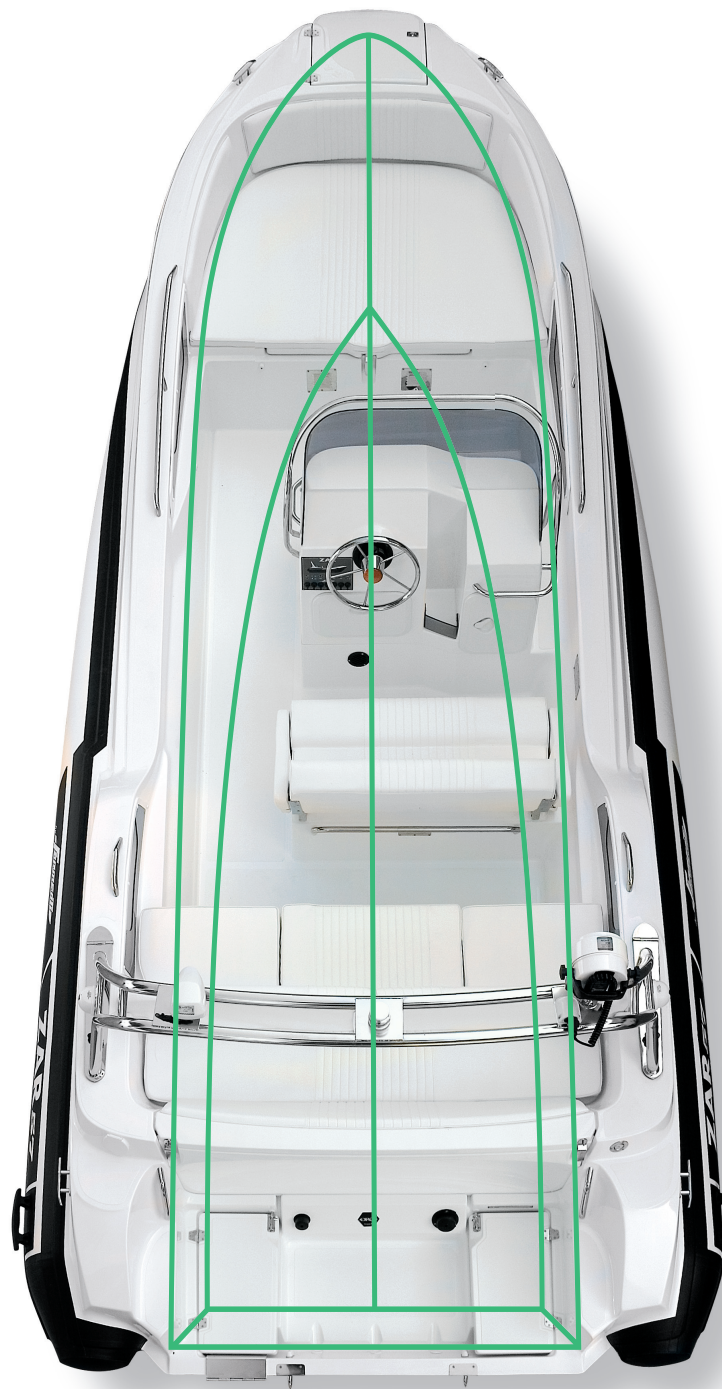

















ZAR 85SL 





My Lady

ZAR 46 SL

SUZUKI







ZAR 85SL 









LINEA ZAR CLASSIC

Sono gli ZAR che hanno fatto la storia. Hanno la classica livrea Bianca e Nera con linea sottobottaccio rossa ma vengono anche declinati in toni di Grigio. Godono delle dotazioni di serie che da sempre tutti gli ZAR hanno avuto e offrono un'ampia gamma di optional a disposizione del cliente per la personalizzare del proprio mezzo.

LINEA CLASSIC LUXURY

È una evoluzione della linea Classic creata per gli utenti più esigenti. Più ricca di accessori di serie (a seconda dei modelli: pannello elettrico, serbatoio, plancette di poppa, timonerie idrauliche...), offre cucinerie in tessuto Carbon Look e volante sportivo.

LINEA SPORT LUXURY

È una linea completamente nuova che riprende inalterate, consolidandole, tutte le caratteristiche vincenti delle blasonate carene ZAR. Introduce innovazioni stilistiche all'avanguardia con una netta denotazione sportiva. Questa linea parte dal progetto ZARTENDER per evolversi negli ZAR 49 SL, ZAR 59 SL e nello ZAR 85 SL. Come nella linea Classic Luxury offre dotazione standard di primo livello, una cura costruttiva quasi maniacale e con finiture di alta classe. Sono ZAR: non poteva essere diversamente.

ZAR CLASSIC LINE

These are the ZARs have made the brand history. They have the classic white and black livery with a red accent stripe, but they also come in gray tones. They offer standard equipments that has always had all ZAR's and a wide range of options available for the customer to customize their boat.

CLASSIC LUXURY LINE

An evolution of the Classic line created for the most demanding users. Enriched with standard accessories (depending on models: electric panel, tank, Swim Platforms, hydraulic steering and more..), also offers Carbon Look Ulphosteries and sports steering.

SPORT LUXURY LINE

A completely new line that resumes unaltered, consolidating, all the winning features of the high-profile ZAR hulls. Introduces cutting-edge styling innovations with a clear denotation for sports. This line starts with the ZAR TENDER project to evolve into ZAR 49 SL, ZAR 59 SL and ZAR 85 SL. As in the Classic Luxury line, it offers standard first-level amenities, almost maniacal-friendly, and high-class design care. It's a ZAR, it could not be different.

GAMME ZAR CLASSIC

Cesont les ZAR qui ont fait l'histoire. Pendant 20 ans ils existaient uniquement dans la déclinaison d'origine noire et blanche avec un liserai orange et depuis quelques années dans la version light grey, un mélange de plusieurs tonalités de gris très élégant. Une large gamme d'options permet de rendre un ZAR à l'image de vos désirs.

GAMME CLASSIC LUXURY

Evolution de la gamme CLASSIC, crée pour les utilisateurs plus exigeants, avec une dotation d'accessoires de série plus riche, des coussins en tissu carbon look et volant sport.

GAMME SPORT LUXURY

C'est une nouvelle gamme de bateaux qui conserve tous les points forts ds ZAR CLASSIC mais avec un design encore une fois innovateur, très racé. Cette nouvelle lignée est l'évolution mnaturelle de notre gamme ZAR Tender. Les modèles existants sont le 49 SL, le 59 SL et le 85 SL. Pareillement à la gamme Classic Luxury, ils possèdent un équipement de série très complet et des finitions de haut niveau.

DIE KLASSISCHE ZAR-SERIE

Die ZAR-Modelle haben Geschichte geschrieben. Sie verfügen über das klassische weiß-schwarze Design mit der roten Scheuerleiste, sind aber auch in Grautönen verfügbar. Die Serie hat die gleiche Serienausstattung, die seit jeher alle ZAR-Modelle haben. Darüber hinaus steht dem Kunden für seine ganz persönliche Bootsausstattung eine breite Palette an Extras zu Verfügung.

DIE KLASSISCHE LUXUSSERIE

Sie ist eine Weiterentwicklung der klassischen Serie für die anspruchsvollsten Kunden. Reicher an Serienzubehör (je nach Modell: elektrische Paneele, Tank, Heckbaudeplattform, hydraulische Steuerung...) bietet sie darüber hinaus Polsterstoffe im Carbon-Look sowie ein sportliches Steuer.

DIE SPORTLICHE LUXUSSERIE

Hierbei handelt es sich um eine komplett neue Serie, die unverändert alle siegreichen und preisgekrönten Eigenschaften der ZAR-Schiffsböden wieder fest aufnimmt. Mit einer rein sportlichen Andeutung führt sie stilistische Neuerungen ein, die ihrer Zeit voraus sind. Das Konzept ZARTENDER ist die Basis dieser Serie und hat in den Modellen ZAR 49 SL, ZAR 59 SL und ZAR 85 SL seine Weiterentwicklung gefunden. Neben der klassischen Luxusserie bietet auch die sportliche Variante eine Standardausrüstung höchsten Grades und einen fast akribischen Bau mit hochwertigen Feinarbeiten. So, wie man es von ZAR kennt und erwartet!



ZAR CLASSIC



ZAR CLASSIC LUXURY



ZAR SPORT LUXURY

ZAR 43



ZAR 43 Classic - Grey

ZAR 47



ZAR 47 Classic - Black & White

ZAR 43

Legenda pag 64 · Legend pag 64 · Légende pag 64 · Legend Seite 64



C

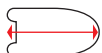

4.56 m
15'



2.20 m
7'3"



4.46 m
14'8"

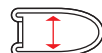

1.60 m
5'3"

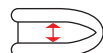

1.18 m
3'10"



n. 6



49 cm
19"



~330 kg
~728 lb



7

HP_{max}

90 CV
67 kW

HP_{OK}

40/70 CV
30/52 kW

HP_{min}

40 CV
30 kW

Optional (C + CL)



~100 lt
~26.4 ga

Optional (C + CL)



~60 lt
~15.8 gal



L

20"



190 kg
419 lb

ZAR 43 Classic - Black & White

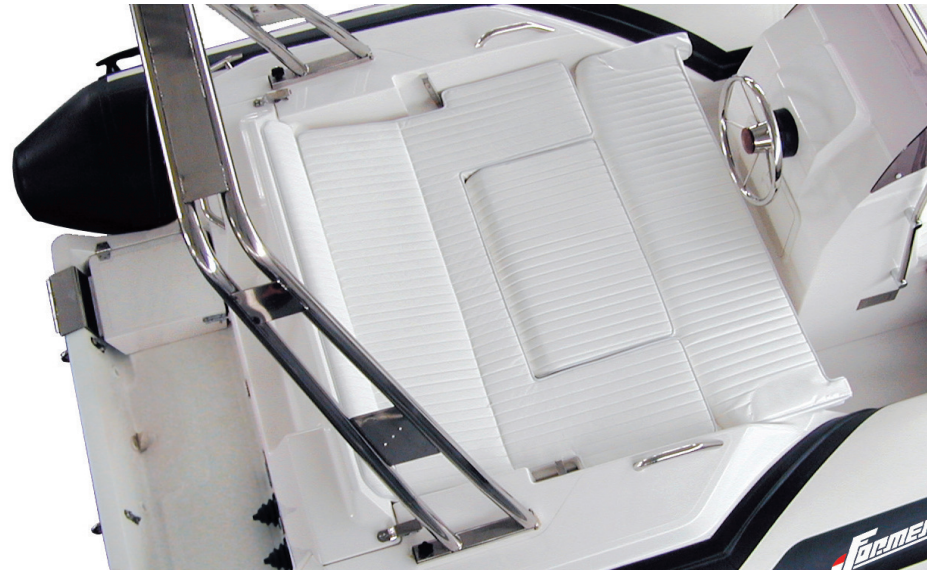

ZAR 47

Legenda pag 64 · Legend pag 64 · Légende pag 64 · Legend Seite 64



C



4.90 m
16'1"



2.32 m
7'7"

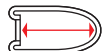

4.80 m
15'9"

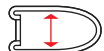

1.80 m
5'11"

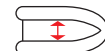

1.28 m
4'2"



n. 6



52 cm
20½"



~380 kg
~838 lb



8

HP_{max}

115 CV
86 kW

HP_{OK}

40/90 CV
30/67 kW

HP_{min}

40 CV
30 kW

Optional (C + CL)



~100 lt
~26.4 gal

Optional (C + CL)



~60 lt
~15.8 gal



L
20"



214 kg
472 lb



ZAR 53 Classic Luxury



ZAR 53 Classic - Black & White





ZAR 57 WD Classic - Grey



ZAR 61



ZAR 61 Classic - Grey

Legenda pag 64 · Legend pag 64 · Légende pag 64 · Legend Seite 64

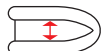
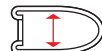
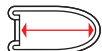

HP_{max}

HP_{OK}

HP_{min}



Optional (C + CL)



C

6.18 m (C) 6.66 m (CL)
20'4" (C) 21'10" (CL)

2.54 m
8'4"

6.00 m
19'8"

1.99 m
6'7"

1.49 m
4'11"

n. 6

53 cm
20 3/4"

~750 kg
~1650 lb

12 (10 Plus)

180 CV
133 kW

130/180 CV
96/133 kW

115 CV
85 kW

~200 lt
~52.8 gal

~67 lt
~17.6 gal

L
20"

240 kg
530 lb



ZAR 61 Classic Plus - Black & White



ZAR65



ZAR 65 Classic - Grey

Legenda pag 64 · Legend pag 64 · Légende pag 64 · Legend Seite 64

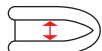
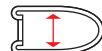
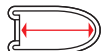

HP_{max}

HP_{OK}

HP_{min}



Optional (C + CL)

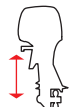

C

6.61 m (C) 7.06 m (CL)
21'9" (C) 23'2" (CL)

2.55 m
8'4"

6.40 m
21'

2.00 m
6'7"

1.50 m
4'11"

n. 6

53 cm
20 3/4"

~880 kg
~1940 lb

12 (10 Plus)

225 CV
166 kW

130/180 CV
96/133 kW

115 CV
85 kW

~250 lt
~66 gal

~67 lt
~17.6 gal

L/XL
20"/25"

400 kg
882 lb



ZAR 65 Classic - Black & White



ZAR 65 Classic - Grey

ZAR 75

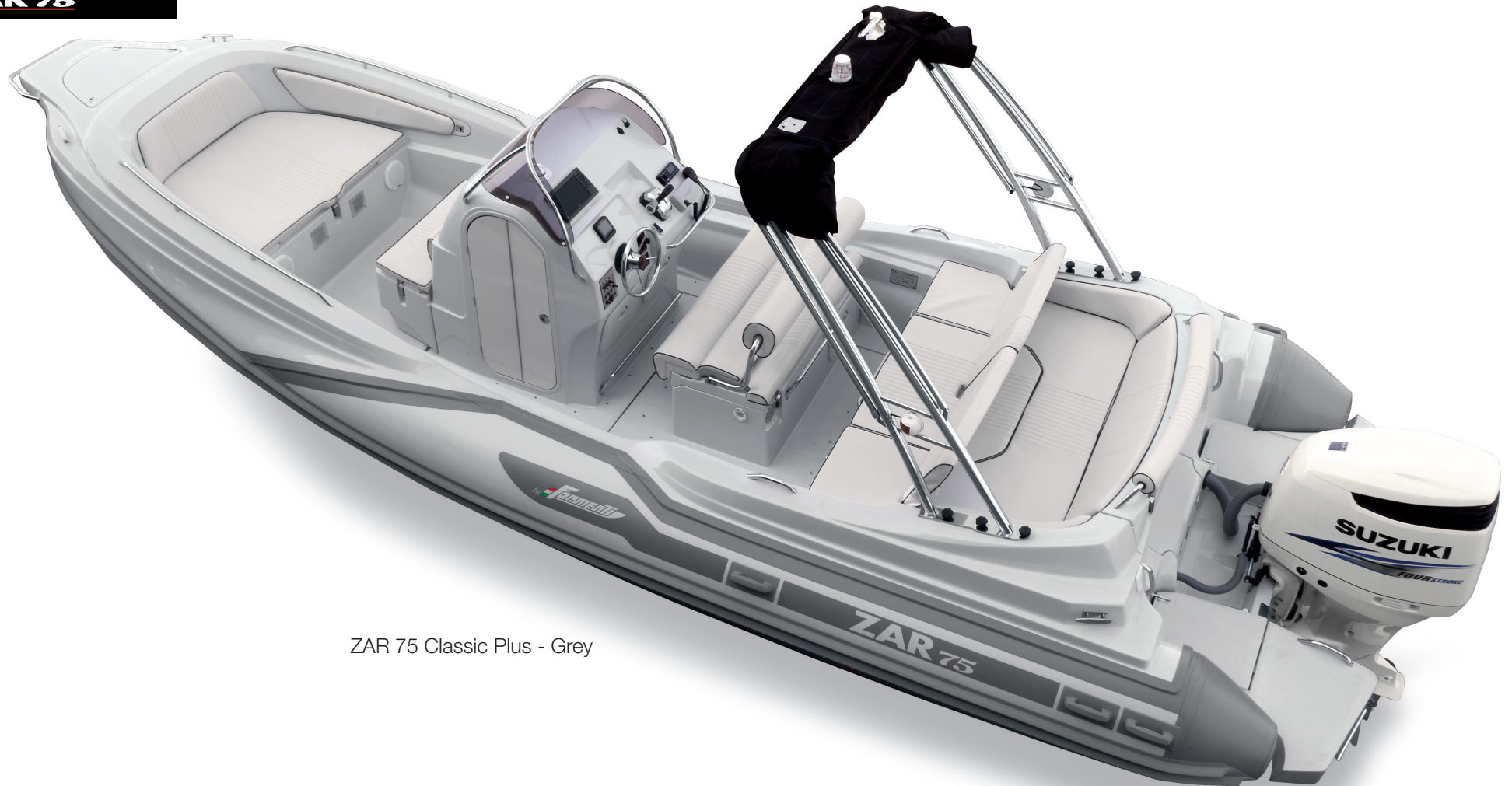

ZAR 75 Classic Plus - Grey

Legenda pag 64 · Legend pag 64 · Légende pag 64 · Legend Seite 64

										HP_{max}	HP_{OK}	HP_{min}				
C	7.40 m (C) 7.72 m (CL) 24'4" (C) 25'4" (CL)	2.86 m 9'5"	7.35 m 24'1"	2.20 m 7'3"	1.68 m 5'6"	n. 6	58 cm 22 3/4"	~1100 kg ~2425 lb	14	300 CV 224 kW	150/250 CV 111/184 kW	130 CV 96 kW	~400 lt (200 Plus) ~105 gal (52.5 Plus)	Optional (C + CL) ~60 lt + ~80 lt ~15.8 gal + ~21.1 gal	XL 25"	480 kg 1058 lb



ZAR 75 Classic Plus - Black & White



ZAR 87 waldeck



ZAR 87 WD Classic - Black & White

Legenda pag 64 · Legend pag 64 · Légende pag 64 · Legend Seite 64



B



8.75 m
28'9"



3.30 m
10'10"



8.70 m
28'6"



2.25 m
7'5"

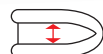

2.00 m
6'7"



n. 6



60 cm
23 3/4"



~2100 kg
~4630 lb



14

HP_{max}

600 CV
448 kW

HP_{OK}

400/450 CV
298/336 kW

HP_{min}

300 CV
225 kW



~550 lt
~145 gal

Optional



~140 lt
~36,9 gal



1 x XXL/2 x XL
1 x 30"/2 x 25"



600 kg
1323 lb



ZAR 87 WD Classic - Black & Neptun Grey

ZAR 87 waldeck





ZAR 49SL 



ZAR 49 SL - White

Legenda pag 64 · Legend pag 64 · Légende pag 64 · Legend Seite 64



C



4.95 m
16'3"



2.16 m
7'1"



4.90 m
16'1"

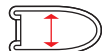

1.74 m
5'9"

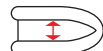

1.13 m
3'8"



n. 6



49 cm
19"



~450 kg
~992 lb



9

HP_{max}

100 CV
74 kW

HP_{OK}

70 CV
52 kW

HP_{min}

40 CV
30 kW

Optional



~100 lt
~26.4 gal

Optional



~60 lt
~15.8 gal

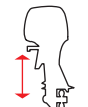

L

20"



190 kg
419 lb



ZAR 49 SL - Black & White



ZAR 59SL 



ZAR 59 SL - Black

Legenda pag 64 · Legend pag 64 · Légende pag 64 · Legend Seite 64



C

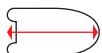

6.09 m
20'



2.43 m
8'



6.09 m
20'



1.80 m
5'11"

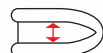

1.35 m
4'5"



n. 6



52 cm
20½"



~590 kg
~1300 lb



11

HP_{max}

150 CV
114 kW

HP_{OK}

115 CV
87 kW

HP_{min}

70 CV
52 kW



~160 lt
~42.2 gal

Optional



~67 lt
~17.6 gal



XL
25"



240 kg
530 lb



ZAR 59 SL - Black



ZAR 59 SL - White

ZAR 59SL 



ZAR 59 SL - White



ZAR 59 SL - White

ZAR 85SL 



Legenda pag 64 · Legend pag 64 · Légende pag 64 · Legend Seite 64



B

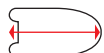

8.72 m
28'7"



3.30 m
10'10"



8.55 m
28'

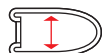

2.20 m
7'3"

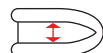

2.20 m
7'3"



n. 6



60 cm
23 3/4"



~1900 kg
~4188 lb



14

HP_{max}

500 CV
347 kW

HP_{OK}

400/450 CV
298/336 kW

HP_{min}

300 CV
225 kW



~400 lt
~105 gal



~100 lt
~24.4 gal

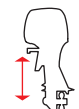

1 x XXL/2 x XL
1 x 30"/2 x 25"



600 kg
1323 lb



ZAR 85SL 





ZAR 85SL 



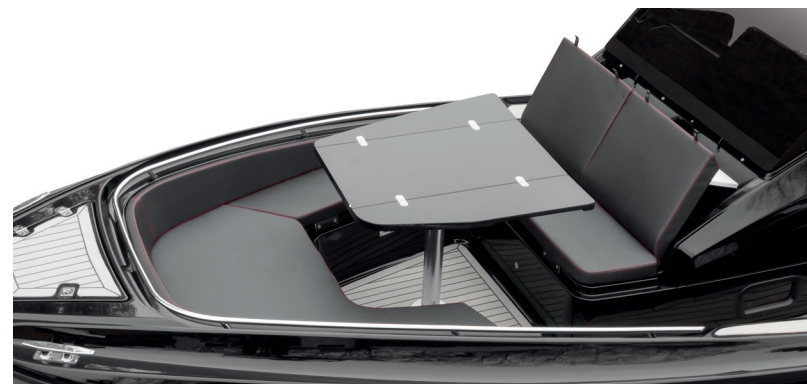
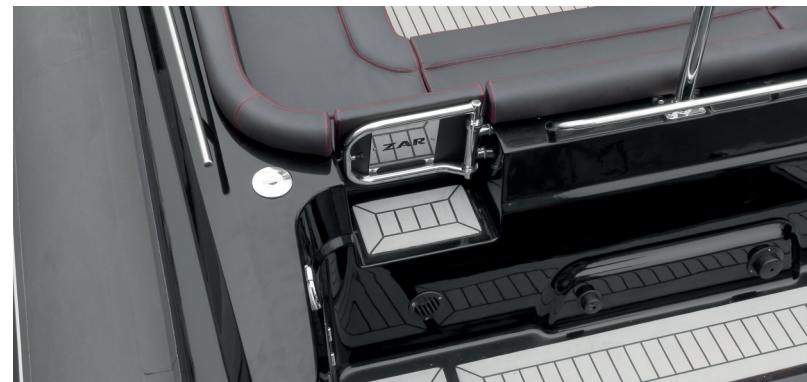

ZAR 73 sky deck



Legenda pag 64 · Legend pag 64 · Légende pag 64 · Legend Seite 64



C

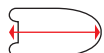

7.30 m
24'



2.54 m
8'4"



7.10 m
23'3"

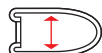

2.00 m
6'7"

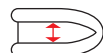

1.50 m
4'11"



n. 6



53 cm
20¾"



~1700 kg
~3750 lb



10

HP_{max}

250 CV
186 kW

HP_{OK}

200/250 CV
148/186 kW

HP_{min}

200 CV
148 kW



~260 lt
~68.5 gal



~70 lt
~18.4 gal



XL
25"



300 kg
661 lb



ZAR97 sky deck



Legenda pag 64 · Legend pag 64 · Légende pag 64 · Legend Seite 64



B



9.70 m
31'10"



3.30 m
10'10"



9.70 m
31'10"

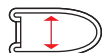

2.30 m
7'7"

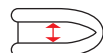

2.05 m
6'9"



n. 6



60 cm
23 3/4"



~2800 kg
~6170 lb



16

HP_{max}

600 CV
448 kW

HP_{OK}

450/500 CV
336/373 kW

HP_{min}

350 CV
261 kW



~600 lt
~158 gal



~140 lt
~36.9 gal



1 x XXL/2 x XL
1 x 30"/2 x 25"



600 kg
1323 lb



ZAR 97 sky deck





ZAR Classic
Standard

ZAR Classic Luxury
Standard

ZAR Sport Luxury (ZAR 49 & ZAR 59)
Standard

Black & White

Grey

White

Black Hull

White Hull

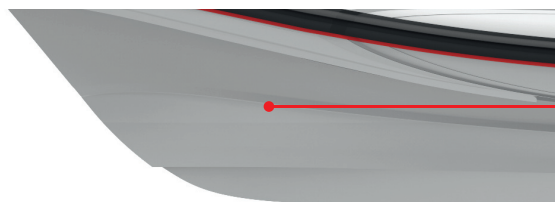

Black



Medium Grey

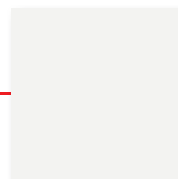

White



Black

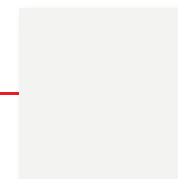

White

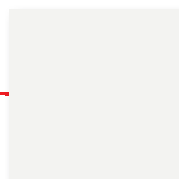
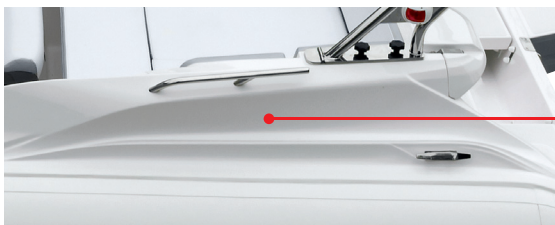

White



Light Grey

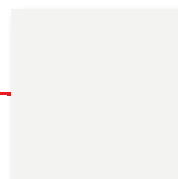

White



White



White



Ice White/Black



Artic Grey/
Neptun grey



Ice White



Ice White/Black



Ice White/
Ice White

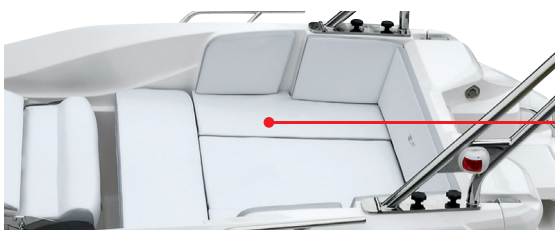

White

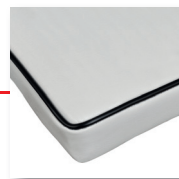

Grey



Carbon
White/Grey



Carbon
White/Grey



Carbon
White/Grey

ZAR Custom colours



White

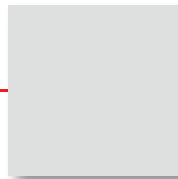

Light Grey

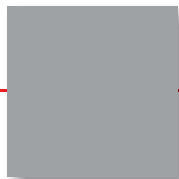

Medium Grey



Dark Grey



Black



White

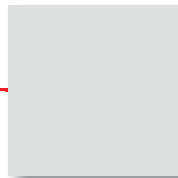

Light Grey

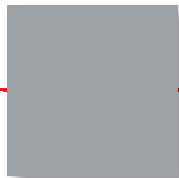

Medium Grey



Dark Grey



Black



Ice White

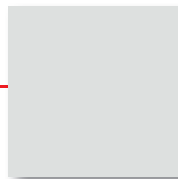

Artic Grey

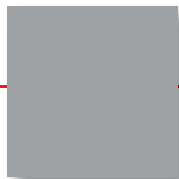

Neptune Grey



Black



Military Grey
Fabric impression



Antracite Grey
Fabric impression

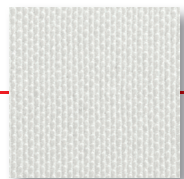

Ice

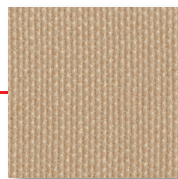

Champagne

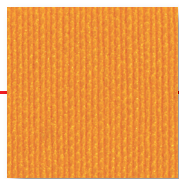

Safran

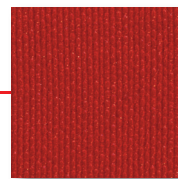

Red

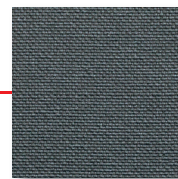

Silvano 11

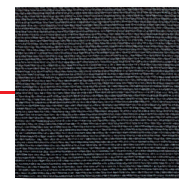

Grafite 19



12571



12572



12576



12577

ZF-0



ZF-1



ZF-2



ZF-3



ZF-5





Alu



Fun



Air

Alu Speed Tubes



Rib Pro

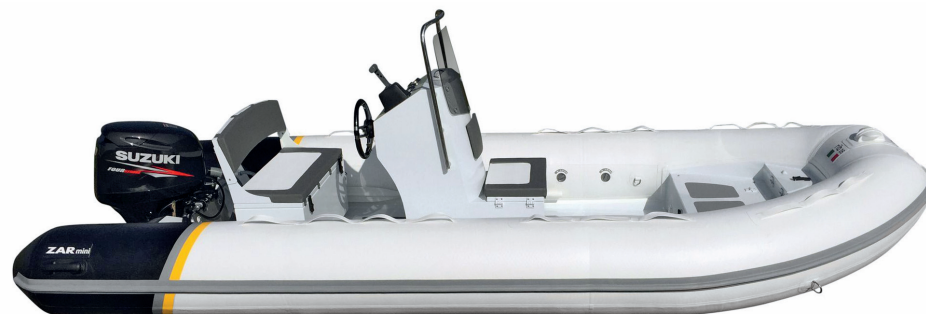

Rib





Categoria di progetto
Category project
Catégorie de projet
Entwurfsklasse



Diametro tubolari
Tube diameter
Diamètre tubulaires
Durchmesser der Schlauchreifen



Capacità approssimativa serbatoio carburante
Approximately fuel tank capacity
Capacité approximative du réservoir carburant
Ungefähre Kraftstofftankkapazität



Lunghezza f.t. (comprese appendici)
Length overall (including appendages)
Longueur hors-tout (appendices compris)
Gesamtlänge (einschl. Anhänger)



Peso a secco (con equipaggiamenti di serie, senza liquidi, senza motore) +/- 10%
Net weight (without equipment, liquids or motor) ± 10% variable datum



Capacità approssimativa serbatoio acqua
Approximately water tank capacity
Capacité approximative du réservoir eau
Ungefähre Wassertankkapazität

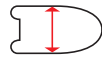

Larghezza max
Max width
Largeur max.
Max Breite

Poids à sec (sans équipements, sans liquides, sans moteur) tolérance ± 10%

Trockengewicht (ohne Ausrüstungen, ohne Flüssigkeiten, ohne Motor) ± 10% variabler Wert



Lunghezza gambo motore
Engine shaft length
Hauteur du tableau de bord
Schaftlänge



Lunghezza interna calpestabile
Internal walking length
Longueur habitable
Rumpflänge



Portata persone
Persons capacity
Nbre de personnes
Sitzplätze



Peso Max motori installabile
Max. installable motors weight
Poids max. moteurs installables
Max. Motorgewicht

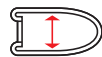

Larghezza interna calpestabile
Internal walking width
Largeur habitable
Innenbreite

HP max

Potenza massima applicabile
Maximum applicable power
Puissance max. applicable
Max. anwendbare Leistung

C = Classic

CL = Classic Luxury

CP = Classic Plus

CLP = Classic Luxury Plus

SL = Sport Luxury

SD = SkyDeck

WD = WellDeck

* = a richiesta, on demand, sur demande, auf Anfrage

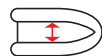

Larghezza intertubolari
Intertubular width
Largeur entre les flottes
Breite zwischen den Schläuchen

HP OK

Potenza consigliata (prestazioni medie)
Recommended power (average performance)
Puissance conseillée (prestations moyennes)
Motorleistung (KW/PS) (empfohlen)



N. Compartimenti stagni
N. tubular compartments
Nbre de compartiments
Luftkammern

HP min

Potenza minima applicabile (prestazioni minime)
Minimum applicable power (minimum performance)
Puissance min. autorisée (prestations minimales)
Motorleistung (KW/PS) min.

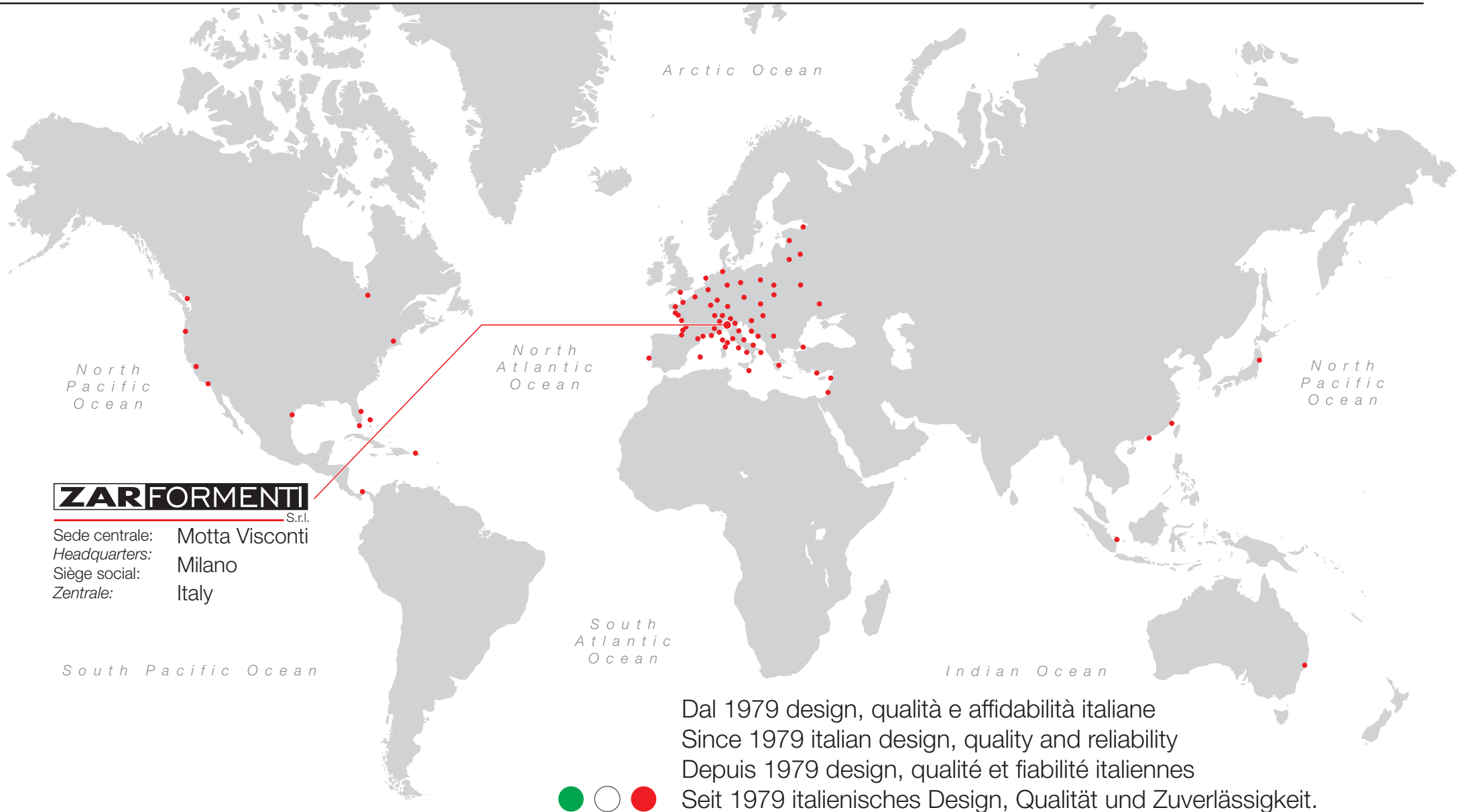

essere avanti
getting ahead
une longueur d'avance
voraus sein

ZAR-FORMENTI S.r.l.

Loc. Vigna della pace, 2/2

Motta Visconti (MI) · Italy

Tel. 02/90000788 · Fax 02/90001850

